

Nov. 10, 1936.

G. S. SUPPIGER ET AL
TABLET DEPOSITING MACHINE

2,060,645

Filed June 13, 1932

4 Sheets-Sheet 1

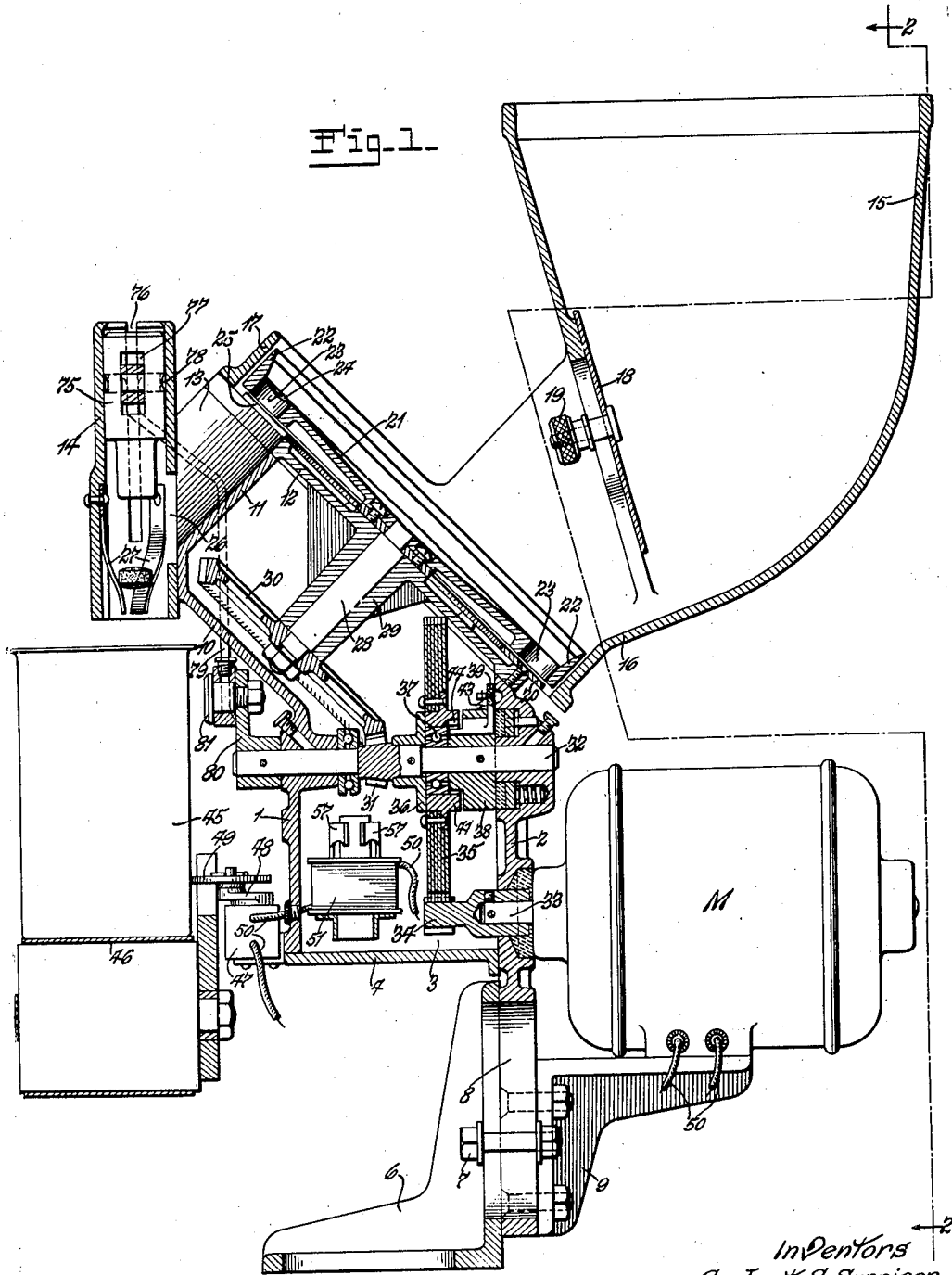

Inventors
Gerhart S. Suppiger
Clode Alexander
John H. Schreiber
by Rippey & Klingland
Their Attorneys.

Nov. 10, 1936.

G. S. SUPPIGER ET AL.
TABLET DEPOSITING MACHINE

2,060,645

Filed June 13, 1932

4 Sheets-Sheet 2

Fig. 2.

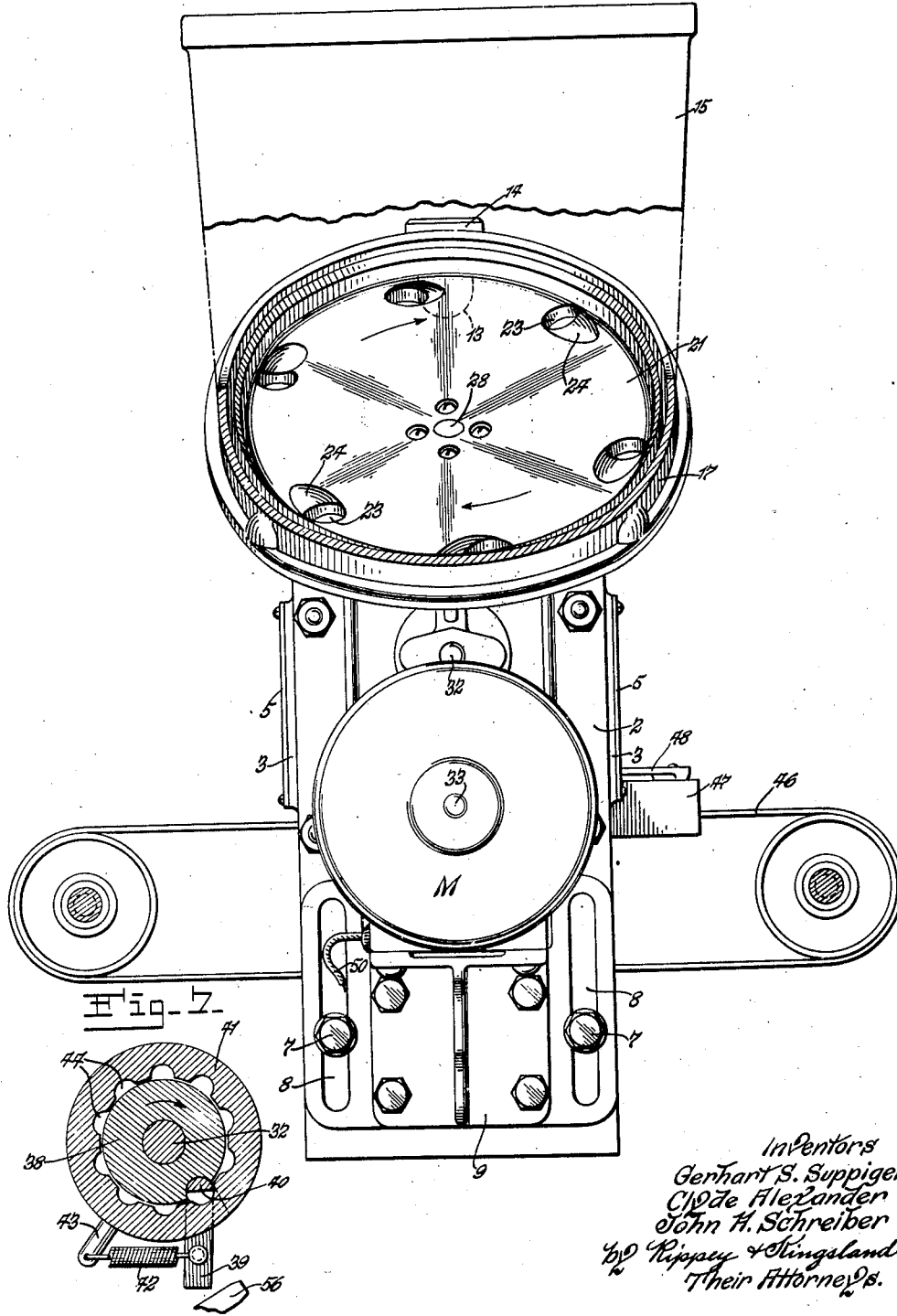

Inventors
Gerhart S. Suppiger
Claude Alexander
John H. Schreiber
by Kippay & Stingsland
Their Attorneys

Nov. 10, 1936.

G. S. SUPPIGER ET AL
TABLET DEPOSITING MACHINE

2,060,645

Filed June 13, 1932

4 Sheets-Sheet 3

Fig. 3-

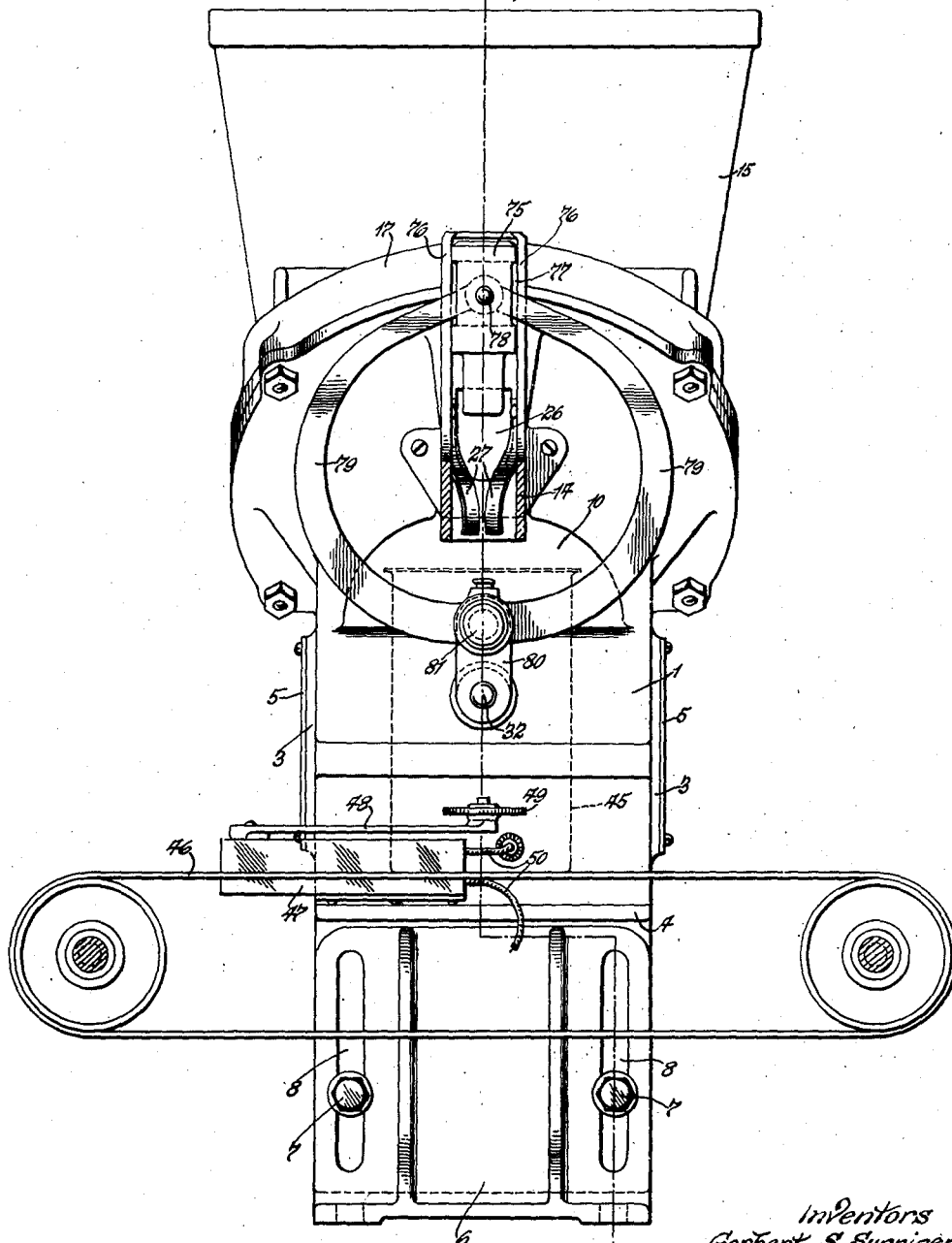

Inventors
Gerhart S. Suppiger
Clarae Alexander
John H. Schreiber
BY Rappaport & Klingeland
Their Attorneys.

Nov. 10, 1936.

G. S. SUPPIGER ET AL

2,060,645

TABLET DEPOSITING MACHINE

Filed June 13, 1932

4 Sheets-Sheet 4

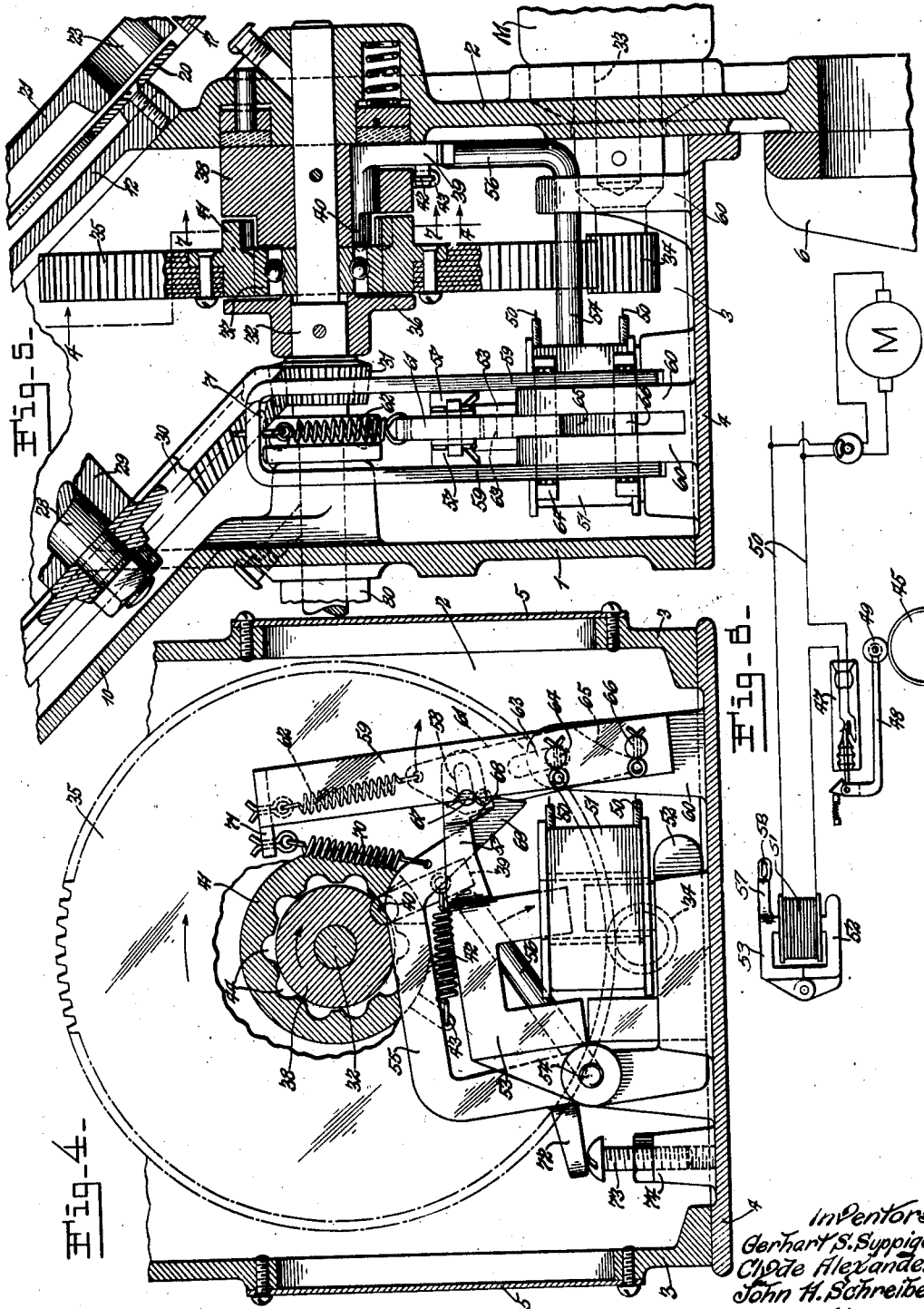

Inventors
Gerhart S. Suppiger
Clare Alexander
John H. Schreiber
By Rippey & Kingsland
Their Attorneys

UNITED STATES PATENT OFFICE

2,060,645

TABLET DEPOSITING MACHINE

Gerhart S. Suppiger and Clyde Alexander, Belleville, Ill., and John H. Schreiber, St. Louis, Mo., assignors to Scientific Tablet Co., Belleville, Ill., a corporation of Illinois

Application June 13, 1932, Serial No. 616,784

11 Claims. (Cl. 226—2)

This invention relates to improvements in tablet depositing machines; and consists in the novel construction hereinafter disclosed.

5 An object of the invention is to provide a machine to separately feed tablets from a supply contained in a hopper at timed intervals to deposit the tablets in containers traversing the delivery point, which machine includes an improved means for separating the tablets one at a time from the bulk of tablets contained in the hopper, and means for depositing the separated tablets in a retaining device from which they are positively expelled by an actuator into containers passing below the delivery device.

15 Another object of the invention is to equip a machine of this class with control mechanism actuated by the several containers into which the tablets are to be deposited, whereby the tablets will be discharged from the machine in synchronism with the position and movement of the containers fed below the machine by any suitable form of conveyor device.

25 Another object of the invention is to improve and simplify the mechanism for separating individual tablets from the bulk contained in the hopper feed device.

Additional advantages of the construction will be apparent from the following detail description taken in connection with the accompanying drawings, in which—

30 Fig. 1 is a vertical section taken substantially on the line 1—1 of Fig. 3.

Fig. 2 is a rear elevation partially in section following the line 2—2 of Fig. 1.

35 Fig. 3 is a front elevation.

Fig. 4 is a transverse section through the machine substantially on the line 4—4 of Fig. 5.

40 Fig. 5 is a view in longitudinal section of the operating mechanism incorporated in the machine.

Fig. 6 is a diagram illustrating the electrical control system.

Fig. 7 is a section on the line 7—7 of Fig. 5.

45 In the embodiment of the invention illustrated in the drawings, the machine is shown as including a housing comprising a front wall 1, a back wall 2 and side walls 3 supported in connection with a removable base plate 4. The side walls have central openings closed by plates 5 so that access to the interior of the housing may be obtained. The back wall 2 is extended downwardly from the base plate and is provided with a bracket 6 adjustably attached to the extension of the back plate 2 by bolts 7 extending through slots 8 in the back plate. A bracket 9 is remov-

ably bolted to the back plate and serves as a support for the operating motor M of the machine. The casting that forms the housing is extended upwardly to provide a forwardly and upwardly inclined housing which includes a bottom wall 10, a generally circular side wall 11 and a top wall 12. The wall 11 at the front part of the machine includes a cylindrical chute 13 that extends obliquely downwardly and forwardly, the lower end of said chute 13 connecting with a vertically disposed cylindrical chamber 14.

The feed hopper includes a generally inverted conical chamber 15 having an open top. The bottom of the hopper is extended to form a semi-cylindrical wall 16 which is formed integral with a flanged annular base 17. At the throat of the chamber 15 is a sliding plate 18 carried by an adjustable thumb screw 19 mounted in a slot in the front wall of the hopper. By vertically adjusting the plate 18 the throat of the hopper may be contracted or protracted to adjust the delivery of the bulk of tablets of different sizes. The base 17 of the hopper construction is carried by the wall 12. The diameter of the base 17 is slightly in excess of the diameter of the wall 12 so that the base 17 overhangs the wall, leaving an open space beyond the periphery of the wall 12. A spacing ring 20 is interposed between the base 17 of the hopper construction and the wall 12. Within the base 17 of the hopper construction there is mounted a circular plate 21 having a vertical flange 22 at its periphery. The upper surface of the plate 21 is formed with a slight concavity so that the rim of the plate is somewhat elevated with respect to the central portion thereof. Adjacent to the periphery of the plate 21 is a circular series of spaced openings 23 the advanced edges of which, as the plate rotates, are formed with a concavity 24 in the upper surface of the plate, which concavity assists in directing the tablets into the openings 23 and also prevents the locking of more than one tablet at a time within the openings.

It will be noted by reference to Fig. 1 that the ring 20 is positioned directly below the circular series of openings 23 and in relatively close adjustment to the lower edge of the openings. The ring 20 is continuous except for that portion of the plate that lies over the upper end of the chute 13, at which point there is an open space 25 in the ring 20. Therefore, when an opening 23 registers with the cut-out portion in the ring 20, the tablet will fall by gravity into the chute 13 and thence through the opening 26 in the wall 55

of the member 14, where it is caught and held by nested spring arms 27.

In operating the feeding mechanism for the tablets, the plate 21 is intermittently revolved. 5 The plate 21 is axially mounted on a shaft 28 revolubly supported in a bearing 29 that extends downwardly from the underface of the wall 12. The shaft 28 carries at its lower end a beveled gear 30. This beveled gear 30 is driven by a beveled 10 pinion 31 carried on a shaft 32 supported in the lower housing of the machine in which it is journaled for rotation. The shaft 32 is intermittently driven from the motor shaft 33 which is constantly rotating. The motor shaft 33 carries 15 a pinion 34 that meshes with a gear 35. The gear 35 has a hub 36 which in turn is carried by the outer ring of an anti-friction bearing 37, either of the ball-bearing or roller-bearing type. Thus the gear 35 constantly rotates its hub during the 20 operation of the machine. The shaft 32 is intermittently connected with the gear 35 by a clutch device. This clutch device includes a collar 38, which is fast with the shaft 32. The collar carries an angular arm, said arm having one leg 39 25 thereof extending outwardly from the periphery of the collar and the opposite leg 40 extending inwardly parallel with the axis of the collar. The inner end of said leg 40 of the arm has a semi-cylindrical extremity that lies within an over- 30 hanging flange 41 on the hub 36 of the gear 35. The outwardly extending leg 39 of the arm has a contraction spring 42 connected therewith at one end, said spring 42 connecting at the oppo- 35 site end with a pin 43 carried by the collar 38. The normal tendency of the spring 42 is to rock the arm so that the edge of the semi-cylindrical portion of the leg 40 will project beyond the pe- 40 riphery of the portion of the collar 38 in which said extension is seated. That portion of the flange 41 of the hub 36 that surrounds the sur- face of the collar 38 is provided with a series of semi-circular notches 44.

The relation of the cooperating parts of the clutch member may be best understood by refer- 45 ence to Fig. 7, from which it will be noted that the extremity of the leg 40 seats in a semi-circular recess in the collar 38 and that, when the spring 42 draws the outwardly extending leg 39 of the arm toward the pin 43, the extremity of the leg 50 40 will rock to a position so that it engages one of the notches 44 and thereby couples the hub 36 of the gear 35 to the collar 38; and, since the collar 38 is fast on the shaft 32, when the parts are in the position shown in Fig. 7 the shaft 32 55 will be rotated. When the parts are in the position shown in Fig. 4, the leg 40 is in a position so that the semi-cylindrical extremity thereof is within the periphery of the collar 38 and the clutch is out of engagement.

60 Since it is desired to synchronize the operation of the driving mechanism with the positioning of the containers below the discharging mechanism of the machine, a control construction operated by contact with the containers is provided.

65 It will be understood that the containers 45 are fed across the machine and below the housing 14 of the discharge member by conveying the containers on an endless belt 46 across the front 70 of the machine. A switch, diagrammatically illustrated in Fig. 6 and indicated by the reference numeral 47, is normally open. It is actuated to closed position by a lever 48 positioned at the front of the machine and carrying a circular disc 49 at its outer end. The lever 48 is spring 75 actuated and, in its normal position, extends

forwardly so that the edge of the disc 49 is in the path of the containers fed to the machine.

As the containers are successively brought under the tablet delivery device, the side walls of the containers contact with the circular disc 49 5 and move the lever 48 inwardly. This inward movement of the lever 48 closes the switch. The switch controls an electrical circuit 50 connected with a coil 51 of a solenoid. Obviously, when the 10 container is in position to receive the discharged tablet, the switch will be closed and the coil of the solenoid energized. The solenoid includes, in addition to the coil 51, a stationary magnet 52 15 which is supported by the base plate 4 of the machine and an armature 53 loosely mounted on a rock shaft 54. The rock shaft 54 also carries a generally U-shaped arm 55 that extends over and beyond the armature 53, said arm being fixed 20 to said rock shaft. The rock shaft 54 has an angular extension 56 the end of which provides a detent for the leg 39 of the clutch arm. The armature 53 is provided with a lateral extension forming an arm 57, which arm 57 has an elongated opening 58 near its extremity.

An inverted U-shaped bracket 59 is supported 25 by spaced lugs 60 extending upwardly from the base plate 4. A latch plate 61 is supported between the arms of the bracket 59, the lower end of the plate extending between the adjacent faces 30 of the lugs 60. The latch plate 61 is actuated by a contractile spring 62, one end of said spring being attached to the upper part of the bracket 59 and the other end of the spring extending 35 through an eye in the upper end of the latch plate. The latch plate has an elongated opening 63 intermediate its length through which a pin 64 supported transversely of the arms of the bracket 59 extends. The lower end of the latch 40 plate 61 has an inclined face 65 that contacts with a pin 66 supported between the arms of the bracket 59, said inclined face 65 cooperating with the pin 66 to cam the latch plate in the direc- 45 tion of the arrow (Fig. 4) when the latch plate is moved downwardly against the tendency of the spring 62.

Near the upper end of the latch plate is a pin 50 67 which extends into the elongated opening 58 in the arm 57 of the armature of the solenoid. The inner edge of the latch plate 61 is provided with a notch 68 which cooperates with a latch 55 hook 69 at the outer extremity of the arm 55. The arm 55 is normally actuated to raised position by a contractile spring 70 connected at one end to said arm and at the opposite end to a 60 lug 71 carried at the upper end of the bracket 59. The extent of upward movement of the arm 55 is regulated by an abutment comprising a lug 72 extending from the arm 55, which lug con- 65 tacts with an adjustable screw 73 mounted in a boss 74 rising from the base plate 4.

In order to understand the operation of the clutch control device, it will be convenient to make reference to Fig. 4, in which the parts de- 70 scribed are shown in released position.

In this view, the solenoid is deenergized and, 75 therefore, the armature 53 is in raised position. The arm 55 is also raised, which rocks the shaft 54 to a position to bring the end of the arm 56 in the path of movement of the leg 39. The direction of rotation of the gear 35 is indicated by the arrow. Obviously, when the clutch is in engagement, the collar 38 will have the same direction of rotation. Therefore, the contact between the end of the arm 56 and the leg 39 will move the leg 39 to a position as shown in Fig. 4, in

which the extremity of the leg 40 is turned so that it is out of engagement with the hub 37 of the gear 35. In this position, the gear 35 is free to rotate without rotating the shaft 32. The latch plate 61 is in its raised position and inclined in the direction opposite to the arrow in Fig. 4, which brings the latch hook 69 into engagement with the notch 68. This, therefore, represents the adjustment of the parts with the clutch out of engagement and the driving mechanism idle.

When a container 45 contacts with the disc 49, the lever 48 is moved inwardly, closing the switch 47 and thereby energizing the coil of the solenoid. This energizing of the coil of the solenoid draws the armature 53 downwardly. As the armature moves downwardly, the arm 57 carried thereby also moves downwardly and, by the pin-and-slot connection with the latch plate 61, moves the latch plate downwardly against the tendency of the spring 62. The lower inclined edge 65 of the latch plate as it moves downwardly is cammed to throw the upper extremity of the plate in the direction of the arrow. The initial downward movement of the latch plate also moves the arm 55 downwardly because of the engagement of the latch hook 69 with the notch 68. The movement of the arm 55 downwardly also moves the arm 56 downwardly and out of the path of the leg 39. As soon as the end of the arm 56 disengages from the leg 39, the spring 42 rocks the leg 40 to the position shown in Fig. 7, thereby coupling the collar 38 with the hub 36 of the gear 35. After the arm 55 has moved downwardly sufficiently to release the arm 56 from engagement with the leg 39, the movement of the latch plate in the direction of the arrow releases the latched engagement of the latch hook 69 with the notch 68 and the arm 55 is snapped upwardly by the spring 70, again bringing the end of the arm 56 into the path of the leg 39 so that, when one revolution of the shaft 32 has taken place, the abutment of the leg 39 against the end of the arm 56 will move the leg 40 again to unlocked position. This action will take place regardless of the position of the armature because the arm 55 is free to move upwardly independent of the armature 53. When the armature 53 is deenergized, the spring 62 will pull the latch plate 61 upwardly and, because of the position of the spring 62 during the upward movement of the latch plate, the latch plate will again move toward the position shown in Fig. 4 and the latch hook 69 will reengage with the notch 68.

It is thus apparent that the construction provides means for imparting a single revolution to the shaft 32 upon each energization of the solenoid and the clutch cannot be reengaged until the solenoid has been deenergized and the armature raised. Therefore, in the event of the containers failing to move out of contact with the switch lever, or if, for any other reason, the solenoid fails to deenergize after the switch has made contact, the depositing mechanism will not operate except to deposit the single tablet upon each energization of the solenoid.

The mechanism for forcing the tablet from the delivery device includes a plunger 75 mounted for vertical reciprocation in the chamber 14. The chamber 14 has registering vertical slots 76 in its side wall and the plunger 75 has a rectangular opening 77 through the body thereof. A pin 78 fitted in the body of the plunger serves as a pivot connection to connect the plunger

with an eccentric strap 79. The upper portion of the strap 79 extends through the slots 76 and the pin 78 passes therethrough. The strap 79 is deflected inwardly at its lower end where it is connected with a crank arm 80 carried by the extremity of the shaft 32, a crank pin 81 serving to form a pivot connection between the crank arm 80 and the strap 79. The crank arm 80 reciprocates the plunger once for each revolution of the shaft 32. The plate 21 driven from the same shaft is driven at a reduced speed ratio so that the revolution of the plate 21 will be in a ratio of one revolution to the number of revolutions of the plunger equivalent to the number of discharge openings 23 in the plate 21. That is to say, the plunger will operate once for each tablet discharged into the tablet depositing device from the feed mechanism.

The plate 21 is so adjusted that the respective discharge openings 23 will register with the opening 25 in the ring 20 to discharge the tablet in the chute 13 as the plunger is moved upwardly. The tablet passes from the chute and is caught below the plunger by the nest of retaining springs 27. The plunger is then depressed, forcing the tablet out of the depositing device during the interval that the next discharge opening 23 is being brought to registration with the opening 25. It will thus be observed that a timed actuator is provided for separately discharging a single tablet for each operation of the feeding mechanism.

From the foregoing description, it will be understood that the general operation of the machine is briefly as follows:

The bulk supply of tablets is placed in the hopper 15. The tablets fall by gravity through the throat of the hopper which is controlled by the sliding plate 18. A quantity separated from the bulk of the tablets deposits upon the lower part of the plate 21. As the plate revolves, single tablets are separated from the bulk and seat in the openings 23, being guided to position by the concavities 24 in the forward edges of said openings. As the plate 21 revolves, the tablets are held in the openings 23 by the ring 20 until the respective openings register with the discharge opening 25 through the ring 20, whereupon they, by gravity, fall into the chute 13 through the opening 26 and into the nest of retaining springs 27. This deposit of the separate tablets occurs as the plunger moves upwardly. During the travel of the plate 21 to bring the next succeeding opening 23 into registration with the discharge opening, the plunger descends, pressing the tablet from its supported position. The movement of the feeding mechanism is accomplished by the setting of the switch 47 to closed position, which energizes the solenoid coil, thereby effecting a coupling of the driving gear 35 driven from the motor with the shaft 32 in such a way that the shaft 32 will make a single revolution, after which the clutch device is thrown to the disengaged position as hereinbefore pointed out in detail.

We are aware that the invention may be modified in numerous particulars without departing from the spirit and scope thereof, and we do not limit ourselves, therefore, to the exact construction shown and described, but what we claim and desire to secure by Letters Patent is:—

1. In a machine for depositing tablets in containers, the combination of a hopper, a unit discharge chamber having a downwardly directed discharge opening, a device for yieldingly holding

articles against passage from said discharge opening, a rotating plate having means for separating unit articles from the bulk of articles delivered from said hopper, a chute between said plate and said unit discharge chamber, whereby unit articles may be conveyed from the plate to the chamber, the yielding holding device containing them in the chamber, a plunger reciprocating in said unit discharge chamber to discharge the unit articles therefrom by overcoming said yielding device, and operating mechanism for said plunger and said plate whereby articles are discharged from said plate for passage to said unit discharge chamber in synchronism with the discharge of unit articles from said unit discharge chamber.

2. In a dispensing machine, the combination of a hopper, a discharge chute, a revoluble plate between the discharge chute and the hopper having a plurality of discharge openings therein for receiving and discharging unit articles, with operating mechanism for said plate comprising a constantly rotating prime mover, a driven shaft, a clutch between the prime mover and the driven shaft, an actuator for the clutch, an electrical solenoid for operating said actuator, a switch for controlling said solenoid, and a lever connected with said switch engageable by containers advanced to the machine to energize the solenoid when a container registers with the discharge chute.

3. In a dispensing machine, the combination of a hopper, a discharge chute, a revoluble plate between the discharge chute and the hopper having a plurality of discharge openings therein for receiving and discharging unit articles, with operating mechanism for said plate comprising a constantly rotating prime mover, a driven shaft, a clutch between the prime mover and the driven shaft, an actuator for the clutch, an electrical solenoid for operating said actuator, a switch for controlling said solenoid, a lever connected with said switch engageable by containers advanced to the machine to energize the solenoid when a container registers with the discharge chute, and a throw-out device for releasing the clutch following the energizing of said solenoid.

4. In a dispensing machine, the combination with a hopper having a downwardly opening discharge throat, of a base connected with the hopper inclining upwardly from the throat of the hopper, a flange on said base member, a revoluble plate mounted on the base the periphery of said plate being within the flange and said plate being provided with a plurality of openings adjacent the outer edge thereof and the surface of the plate being convex, a discharge chute connected with the upper portion of said base, an article delivery chamber connected with said chute, said chamber having a downwardly directed discharge opening, retaining means preventing the movement of articles through said discharge opening, an actuator for releasing the articles from said retaining means, operating mechanism for said plate and for said actuator for releasing articles from said retaining means and delivering articles to said chute in timed relation, and a control device under the influence of the movement of containers to said machine for controlling said actuator.

5. In a machine for depositing tablets in substantially filled containers, having a discharge opening under which such containers are moved, and means for feeding tablets singly toward said opening in an oblique direction thereto, a cham-

ber immediately above said opening, communicating therewith and adapted to receive tablets fed by said means, a yielding device in said chamber adapted to retain a tablet fed by said means in a vertical line above said opening, a plunger adapted to be reciprocated in said vertical line and to discharge such tablet from the yielding device in a vertical line to a container under said opening, and mechanism for operating said plunger and said feeding means in timed relationship.

6. In a depositing machine, a plate for feeding tablets, a chute into which said plate discharges said tablets, an elongated chamber having an inlet passage in a wall, said passage being spaced from the end of the chamber, the chute communicating with the interior of said chamber through said passage, said elongated chamber having an opening in the bottom thereof through which the tablets may be discharged, resilient means extending inwardly from the walls of the chamber, and adapted yieldingly to hold the tablet from passing through the discharge opening, and a plunger in the chamber normally above the inlet passage, and reciprocable in said chamber to force the tablet therefrom.

7. In a machine for depositing tablets in a container, a rotary plate for separating individual tablets from a mass thereof, a discharge chamber having a discharge opening in the bottom thereof, fixed means conducting said individual tablets from said plate to said chamber, means in said chamber resiliently to retain the tablet from passing out said discharge opening, a plunger in said chamber adapted to reciprocate and force the discharge of the tablet against the action of said retaining means, a motor, driving means between said motor and said rotary plate whereby to rotate the plate, a driving means between the motor and the plunger whereby to actuate the plunger to discharge the tablet in synchronism with the action of the plate, and means actuated by the container when the same is in receiving position to control said driving means.

8. An apparatus for intermittently depositing tablets into containers, including a retainer having a discharge opening therein from which a tablet may be discharged into a container located in receiving relation therewith, means discharging the tablet from said retainer, a driving means therefor, a control device having an element moved by the container, in position, a mechanism for connecting said driving means with said discharge means, and releasable means interposed between said control device and said connecting mechanism so that said control device upon movement by the container causes said connecting mechanism to be actuated for driving the discharge means, said interposed means being automatically released after each actuation to break connection between the control device and the connecting mechanism regardless of the position of the said control device.

9. An apparatus for depositing tablets into containers, including a retainer having a discharge outlet from which a tablet may be discharged into a container located in receiving relation therewith, means discharging the tablet from said retainer, a driving means engageable therewith for actuation thereof, a clutch interposed between the driving means and the discharging means, and mechanism for controlling the clutch, said mechanism including an electromagnet, a switch operated by the con-

tainer in position to energize said electromagnet, an armature moved by said magnet, a clutch control device movable to position to permit engagement of the clutch, and means connecting the armature with the clutch control device during a portion of the movement of the armature to move the same and permit engagement of the clutch, and releasing the clutch control device after said portion of the movement of the armature whereby the clutch will be released regardless of the position of the armature.

10. An apparatus for depositing tablets into containers including means, having a discharge portion, for depositing a tablet into a container located in receiving relation to said discharge portion, means adapted to actuate said depositing means, and control mechanism for selectively causing said actuating means to operate the depositing means only for a predetermined operation, said control mechanism including a movable element, means in said mechanism operating said element by a container in the relation aforesaid, to a position wherein to permit said actuating means to operate the depositing means for said predetermined operation, and means in said mechanism releasing said element so that it may render the actuating means ineffective

after said predetermined operation to operate the depositing means until the element operating means is returned to its starting position.

11. An apparatus for depositing tablets into containers including means, having a discharge portion, for depositing a tablet into a container located in receiving relation to said discharge portion, normally disconnected means adapted when connected therewith, to actuate said depositing means, mechanism for selectively controlling the connection of said actuating means to said depositing means, said control mechanism having an element operable to a position wherein the actuating means may be connected to the depositing means, and said mechanism having means operable from an initial position to move said element to said position, said means being operated by the presence of a container in the relation aforesaid, and said means releasing said element to position wherein to cause disconnection of said actuating means and said depositing means upon a predetermined operation of the latter, said element moving means being inoperable to move said element again until returned to said initial position.

GERHART S. SUPPIGER.
CLYDE ALEXANDER.
JOHN H. SCHREIBER.