

[54] PNEUMATIC DEVICE FOR MOVING ARTICLES

2,446,657 8/1948 McLeod..... 91/DIG. 4
2,996,330 8/1961 Hutto..... 214/1 CM
3,168,203 2/1965 Gallistel..... 214/1 CM

[76] Inventor: George Carroll, 12 Palmerston, Stockport, England

Primary Examiner—Gerald M. Forlenza
Assistant Examiner—George F. Abraham
Attorney—Francis C. Browne et al.

[22] Filed: Feb. 17, 1972

[21] Appl. No.: 227,570

[30] Foreign Application Priority Data

Feb. 18, 1971 Great Britain..... 4,890/71

[52] U.S. Cl..... 214/1 BB, 91/DIG. 4, 92/169

[51] Int. Cl..... F01b 11/00

[58] Field of Search..... 214/1 BB, 1 BT;
294/65.5; 91/DIG. 4; 92/169, 170

[56] References Cited

UNITED STATES PATENTS

3,390,580 7/1968 Taylor..... 92/5 R X

[57] ABSTRACT

A device for moving articles comprising a cylinder of non-ferrous material, a piston including a magnet movable within said cylinder, means for controlling the admission of pressure fluid to the cylinder for moving said piston and a body disposed outside and adjacent to said cylinder, said body including a magnet, the arrangement being such that movement of said piston causes a corresponding movement of said body.

8 Claims, 6 Drawing Figures

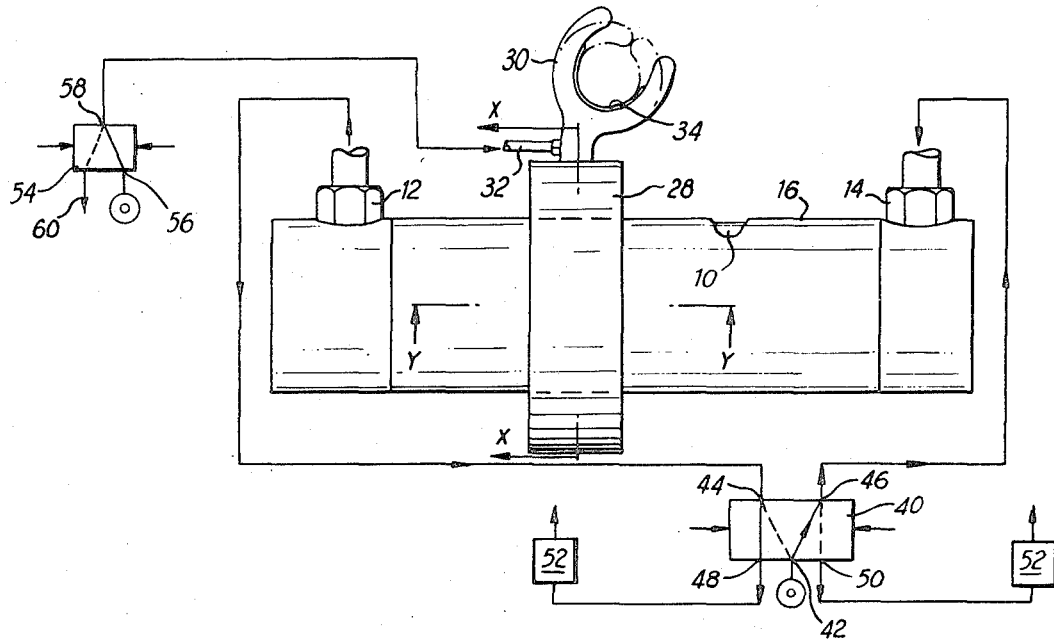

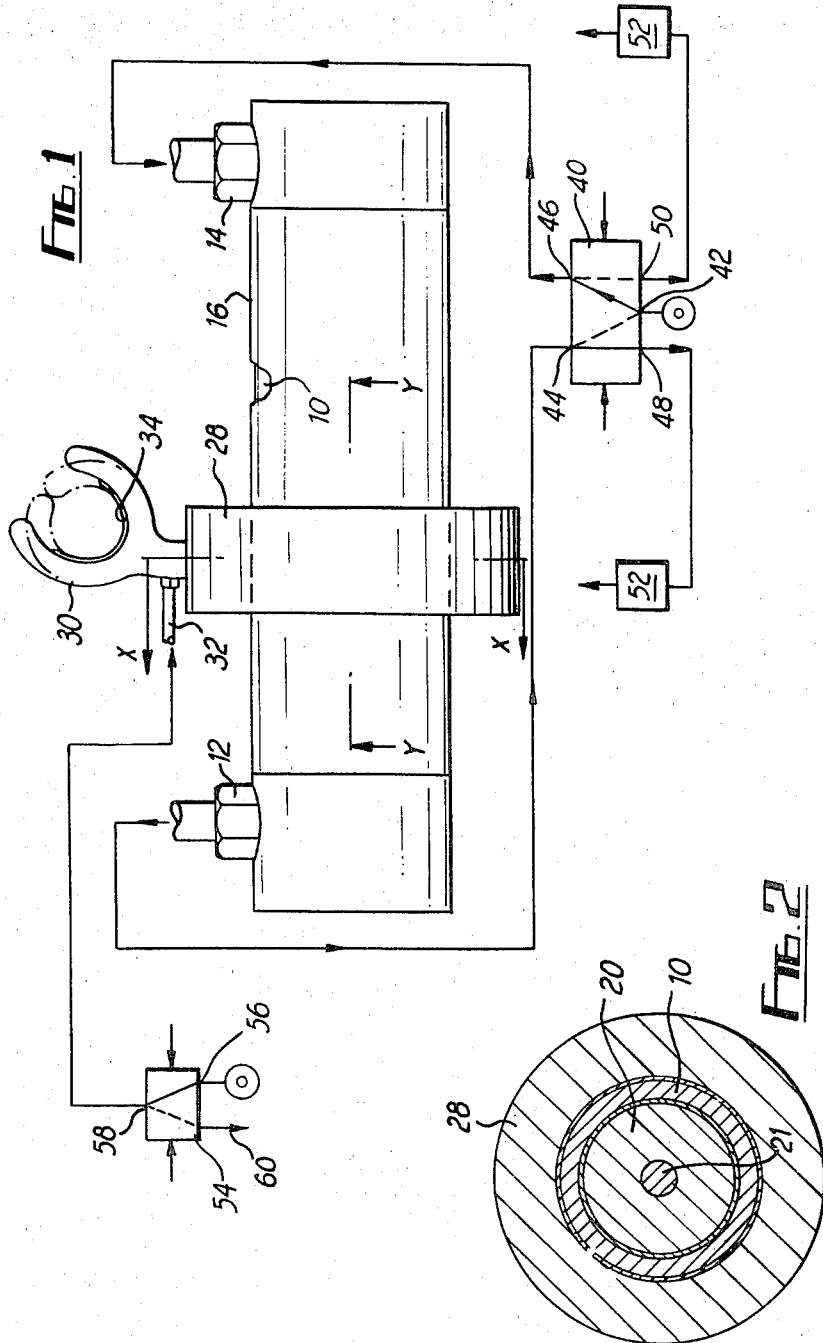

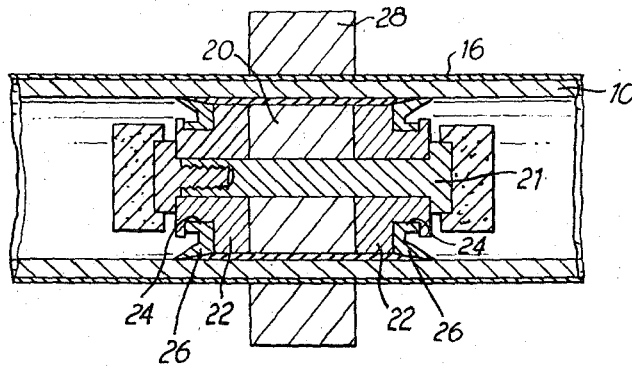

FIG. 3

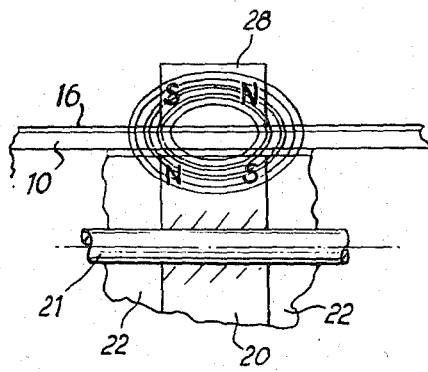

FIG. 4

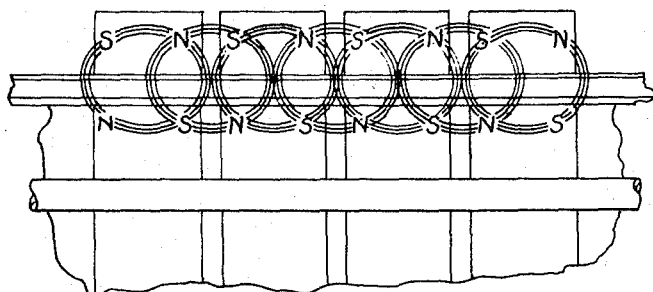

FIG. 5

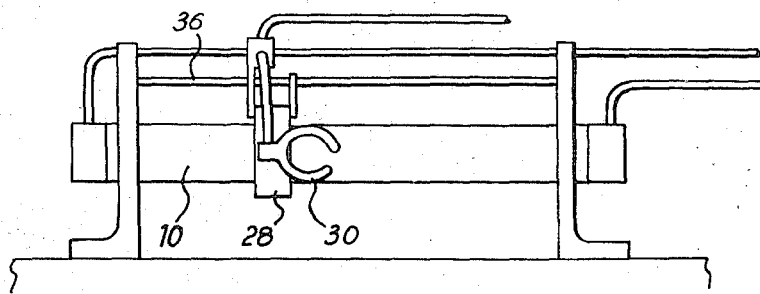

FIG. 6

PNEUMATIC DEVICE FOR MOVING ARTICLES

This invention relates to a magnetic device for moving articles and in particular for moving articles of clothing.

It has previously been proposed to provide pneumatic devices which include a cylinder and a piston mounted on a piston rod working in said cylinder. Such devices suffer from the disadvantage that considerable space is required to accommodate the piston rod. Such a distance being up to twice the distance through which an article may be moved by the device.

Further, in the clothing industry in particular, very light loads are required to be moved preferably at high speeds or at both high speeds and slower speeds during transfer of an article from one site to another. Devices as previously proposed cannot operate in accordance with these requirements.

The present invention has been made from a consideration of the aforesaid disadvantages.

According to the invention there is provided a device for moving articles comprising a cylinder of non-ferrous material, a piston including a magnet movable within said cylinder, means for controlling the admission of pressure fluid to the cylinder for moving said piston and a body disposed outside and adjacent to said cylinder, said body including a magnet, the arrangement being such that movement of said piston causes a corresponding movement of said body.

In a preferred embodiment of the invention the body comprises an annular magnet surrounding the cylinder having means mounted thereon for holding or supporting an article. Inlets for pressure fluid are preferably provided at each end of the cylinder and the input and/or exhaust of pressure fluid to the cylinder is preferably controlled by a valve. Means may also be provided for adjusting the conditions of pressure fluid within the cylinder so that the piston movement can be halted during travel from one end of the cylinder to the other and/or so that the speed of the piston during travel of the cylinder can be varied.

The pressure fluid employed in the present invention is preferably compressed air so that the device is pneumatic. It is however possible for the pressure fluid to be a liquid so that the device is hydraulic.

The invention is particularly adapted to move light loads such as articles of clothing at high speeds and for this purpose the means for holding or supporting the article is preferably a resilient pneumatically operable gripping device.

A specific embodiment of the invention will now be described by way of example with reference to the accompanying drawings in which:

FIG. 1 shows the device and associated control means schematically;

FIG. 2 is a section on the line X—X of FIG. 1;

FIG. 3 is a section on the line Y—Y of FIG. 2.

FIG. 4 shows the magnetic field using a single magnet;

FIG. 5 shows the magnetic field where a plurality of magnets are employed; and

FIG. 6 shows the device in plan view.

Referring to the drawings the device comprises a cylinder 10 of non-ferrous material having parts 12 and 14 adjacent each end. A coating 16 of material having a low coefficient of friction, such as polytetrafluoroethylene, is formed on both outer and inner surfaces

of said cylinder. A piston 18 is located in the cylinder, the piston comprising a cylindrical permanent magnet 20, having a diameter less than the internal diameter of the cylinder 10, clamped between two non-ferrous piston end members 22, of substantially cylindrical shape but of overall diameter less than the internal diameter of the cylinder. The magnet 20 and piston end members are held together by means of a bolt 21 passing through a bore in the magnet and end members.

Each end member has an annular groove 24 therearound which accommodates a resilient sealing ring 26 adapted to engage the inner wall of the cylinder and form a fluid tight seal. Cushions of resilient material are fixed to each end member, or as shown in FIG. 2 to the head of the bolt 21 to prevent damage to the device when the piston reaches the ends of the cylinder.

A permanent magnet 28 of annular shape surrounds the cylinder with minimum clearance, the polarisation of magnets 20 and 28 being such that movement of the piston, and hence magnet 20 within the cylinder causes corresponding movement of magnet 28 outside the cylinder (see FIG.4). piston, and hence magnet 20 within the cylinder causes corresponding movement of magnet 28 outside the cylinder (see FIG.4).

A pneumatically operable article gripping device 30 is mounted on magnet 28. The gripper device 30 comprises a hollow substantially U-shaped body of resilient material, such as rubber, having an inlet 32 for pressure fluid. The U-shaped body is held in shape by means of light porous reinforcing material therewithin. A strip of material 34 is bonded to the body between the arms thereof, said material being material of less elasticity than that of the body so that when pressure fluid is admitted through inlet 32 the arms of the U-shaped body will bend inwards towards each other (as shown in dotted lines in FIG.1) and will grip any article therebetween. In order to prevent the magnet 28 rotating relative to the cylinder a guide rod 36 (FIG.6) is mounted outside the cylinder and axially parallel thereto, a tie bar 38 being fixed to the magnet and having a hole bore therein which runs freely on the guide rod.

The device is controllable by means of a five part spool valve 40 which has a port 42 connected to a supply of compressed air (not shown), port 44 connected to cylinder port 12, port 46 connected to cylinder port 14 and exhaust ports 48 and 50. As shown in FIG. 1 the spool valve is in position to supply compressed air to cylinder port 14 and cylinder port 12 is connected to exhaust port 48 so that the piston, and with it magnet 28 and gripping device 30, is moved to the left (as viewed in the drawing). On reversing the spool valve compressed air will be supplied to cylinder port 12 and cylinder port 14 will be connected to exhaust port 50 so that the piston moves towards the right. The exhaust ports of valve 40 are preferably connected to variable restrictor mechanisms 52 which are automatically operable to control the exhaust from the valve 40 and hence the speed of the piston in the cylinder.

The supply and exhaust of pressure air to the gripping device 30 is controlled by a spool valve 54 having a port 56 connected to a compressed air supply (not shown), a port 58 connected to inlet 32 and an exhaust port 60. The movement of the magnet 28 along the cylinder can be used to generate signals for operating the valve 54 and if desired the restrictor mechanisms 52 and valve 40.

As illustrated in FIG. 5 more than one magnet may

be provided on the piston and/or around the cylinder.

It is, however, preferred to arrange that the magnetic force between the magnets should not be greatly in excess of that required to move the articles required to be transported. Thus should magnet 28 be obstructed by a person or by some object the piston can still move to the end of the cylinder without any damage to the device and without injury to the person or object.

The device according to the invention is capable of high speed operation, the speed of travel of the piston in the cylinder being a function of the volume of air admitted through the inlet port and exhausted through the exhaust port, this itself being a function of the size of the ports. By appropriate dimensioning of the ports it has been possible without difficulty to move a piston from one end of a 20 foot cylinder to the other end thereof in about 7 seconds.

The device may be used not only for the transfer of articles of clothing, but may be used to carry any article from one site to another along a predetermined path. Thus while the specific embodiment describes an arrangement suitable for transferring an article along a linear path, it is possible to shape the guide rod for example in the form of a helix so that the body will follow a helical path.

In the embodiment described with reference to the drawings a polytetra fluoroethylene coating is applied to the outer surface of the cylinder to provide a low friction surface upon which the body may run. As an alternative it is possible to provide an air bearing between the body and the cylinder. Further it is possible to use the repulsive force of magnets located in longitudinal grooves in the surface of the cylinder and further magnets disposed in the body which maintain the body spaced - apart from said cylinder.

If the device is designed for operation at high speeds, it may be found that the piston is decelerated too abruptly on reaching the end of the cylinder. Better control over deceleration of the piston may be accomplished by coupling the port which is exhausting to a chamber or cylinder containing a non-compressible fluid such as water.

The operation of the device may be triggered by any suitable means such as a timing device and/or a device

sensitive to the presence, at one end of the device, of an article to be transferred thereby.

What is claimed is:

1. A device for moving articles comprising a cylinder of non-ferrous material, a piston including a permanent magnet having a pole-piece on each axial side thereof, a body disposed outside and adjacent to said cylinder, said body including a permanent magnet which substantially surrounds the cylinder, there being a pole piece on each axial side of the permanent magnet included in said body, and means for controlling the admission of pressure fluid into the cylinder and exhaust of fluid from the cylinder for moving the piston in the cylinder, the attractive forces between the permanent magnets being such that movement of the piston causes corresponding movement of the body below a predetermined load on the body and such that above said predetermined load movement of the piston does not cause corresponding movement of the body.

2. A device as claimed in claim 1, wherein the body comprises an annular magnet surrounding the cylinder and means for holding or supporting an article.

3. A device as claimed in claim 2, wherein the means in said body for holding an article comprises a pneumatically operable gripping means.

4. A device as claimed in claim 3, wherein at least a part of the gripping means is adapted to grip an article and is made of resilient material.

5. A device as claimed in claim 1 wherein a port is provided at each end of the cylinder for the input of pressure fluid to, and exhaust of pressure fluid, from the cylinder.

6. A device as claimed in claim 5, wherein a valve is provided for controlling the input of pressure fluid and the exhaust of pressure fluid from the cylinder to thereby control the movement of the piston in the cylinder.

7. A device as claimed in claim 1 in which said body including the permanent magnet surrounds the cylinder.

8. A device as claimed in claim 1 in which the piston includes a plurality of permanent magnets.

* * * * *

45

50

55

60

65

REEXAMINATION CERTIFICATE (935th)

United States Patent [19]

[11] **B1 3,779,401**

Carroll

[45] Certificate Issued **Oct. 25, 1988**

[54] **PNEUMATIC DEVICE FOR MOVING ARTICLES**

[58] **Field of Search** 414/3, 749, 751;
91/DIG. 4; 92/85 R, 169, 170; 198/619;
104/154, 156

[75] **Inventor:** George Carroll, Stockport, England

[56] **References Cited**

[73] **Assignee:** Festo KG, Esslingen-Berkheim, Fed. Rep. of Germany

U.S. PATENT DOCUMENTS

1,162,562 11/1915 Brown 92/85 R
2,446,657 8/1948 MacLeod et al. 91/DIG. 4
2,996,330 8/1961 Hutto 414/751 X
3,168,203 2/1965 Gallistel 414/5
3,390,580 7/1968 Taylor 92/5 R X
4,488,477 12/1984 Miyamoto 91/DIG. 4

Reexamination Request:
No. 90/001,477, Mar. 18, 1988

FOREIGN PATENT DOCUMENTS

1982379 3/1968 Fed. Rep. of Germany .

Reexamination Certificate for:
Patent No.: **3,779,401**
Issued: **Dec. 18, 1973**
Appl. No.: **227,570**
Filed: **Feb. 17, 1972**

Primary Examiner—L. J. Paperner

[57] **ABSTRACT**

A device for moving articles comprising a cylinder of non-ferrous material, a piston including a magnet movable within said cylinder, means for controlling the admission of pressure fluid to the cylinder for moving said piston and a body disposed outside and adjacent to said cylinder, said body including a magnet, the arrangement being such that movement of said piston causes a corresponding movement of said body.

[30] **Foreign Application Priority Data**

Feb. 18, 1971 [GB] United Kingdom 4890/71

[51] **Int. Cl.⁴** F01B 11/00

[52] **U.S. Cl.** 414/751; 91/DIG. 4;
92/169; 198/619

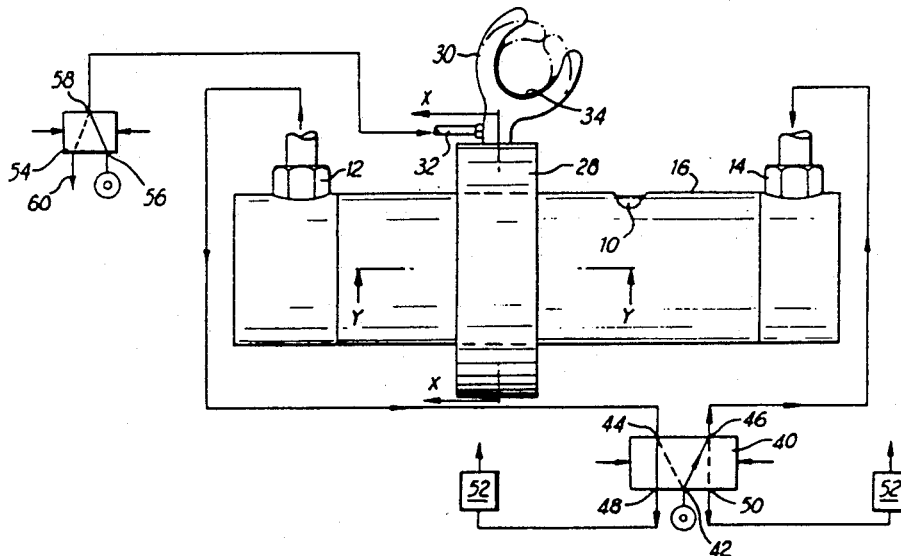

REEXAMINATION CERTIFICATE
ISSUED UNDER 35 U.S.C. 307

THE PATENT IS HEREBY AMENDED AS
INDICATED BELOW.

Matter enclosed in heavy brackets [] appeared in the patent, but has been deleted and is no longer a part of the patent; matter printed in italics indicates additions made to the patent.

AS A RESULT OF REEXAMINATION, IT HAS
BEEN DETERMINED THAT:

Claims 1, 2, 7 and 8 are cancelled.

Claims 3 and 5 are determined to be patentable as amended.

Claims 4 and 6, dependent on an amended claim, are determined to be patentable.

New claim 9 is added and determined to be patentable.

3. A device as claimed in claim [2] 9 wherein the means [in] on said body for holding an article comprises a pneumatically operable gripping means.

5. A device as claimed in claim [1] 9 wherein a port is provided at each end of the cylinder for the input of pressure fluid to, and exhaust of pressure fluid, from the cylinder.

9. A device for moving articles, which comprises:
a hollow cylinder formed of non-ferrous material and having opposite axial ends;
a piston mounted in the interior of the hollow cylinder and reciprocatingly slidable therein, the piston includ-

ing a central mounting member disposed axially in the cylinder, a plurality of cylindrically-shaped permanent magnets mounted on the central mounting member and spaced apart axially from each other, each magnet having a bore formed axially there-through for receiving the central mounting member, at least one pair of end members mounted on the central mounting member and disposed on opposite axial sides of the plurality of magnets, a pair of cushion members formed of resilient material, the cushion members being situated near opposite axial ends of the central mounting member to help prevent damage to the piston when the piston contacts an axial end of the cylinder, and a pair of resilient sealing rings situated near opposite axial ends of the central mounting member and engaging the cylinder to effect a fluid-tight seal therewith;

a body mounted on the exterior of the hollow cylinder and reciprocatingly slidable thereon, the body including a plurality of annularly shaped permanent magnets surrounding the cylinder and spaced apart from each other, the permanent magnets of the piston and body being polarized so as to magnetically couple the body to the piston whereby movement of the piston inside the cylinder causes a corresponding movement of the body outside the cylinder, the body further including means provided thereon for holding on the body an article to be moved; and

means for controlling the admission of pressure fluid into the cylinder and exhaust fluid from the cylinder for moving the piston in the cylinder, the attractive forces between the permanent magnets of the piston and the body being such that movement of the piston causes corresponding movement of the body below a predetermined load on the body and such that above said predetermined load movement of the piston does not cause corresponding movement of the body.

* * * * *

40

45

50

55

60

65